

JOB NUMBER -		THE CONTENTS OF THIS DRAWING REMAIN SOLELY THE PROPERTY OF BARTON ADT ENGINEERING. THIS DRAWING OR ITS CONTENT MAY NOT BE COPIED OR REPRODUCED WITHOUT THE PRIOR WRITTEN APPROVAL OF BARTON ADT ENGINEERING	
OFFICE	WORKSHOP	3rd ANGLE PROJECTION	DRAWN - john kember
DATE ISS'D	DATE FAB'D		CREATED -
QTY. REQ'D	QTY. FAB'D	ALL DIMENSIONS ARE IN MILLIMETRES U.O.N.	CHECKED -
			APPROVED -
SCALE: AS NOTED			

VOLVO A30G SURFACE WATER TANK ASSY
27000 LT NOMINAL CAP

BARTON ADT ENGINEERING
ADT SERVICE MODULES AND WATER TANKERS

BARTON ADT ENGINEERING
EMAIL sales@bartonadtengineering.com
PHONE (+61) 40772864
WEB www.bartonadtengineering.com

DRG. VOLVO A30G ASSY 013	SHT. 1 of 2	SIZE A1	REV. A
--------------------------	-------------	---------	--------

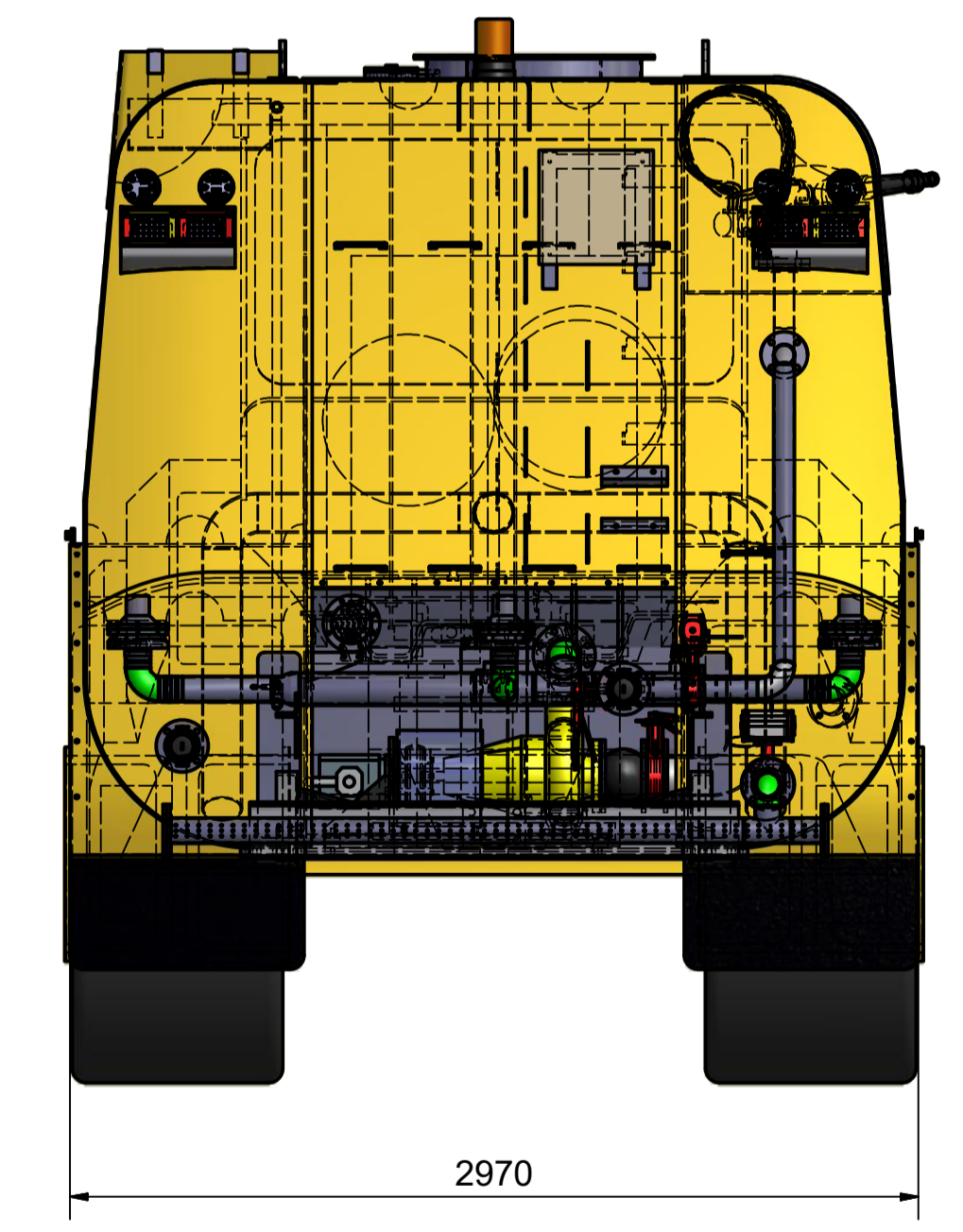
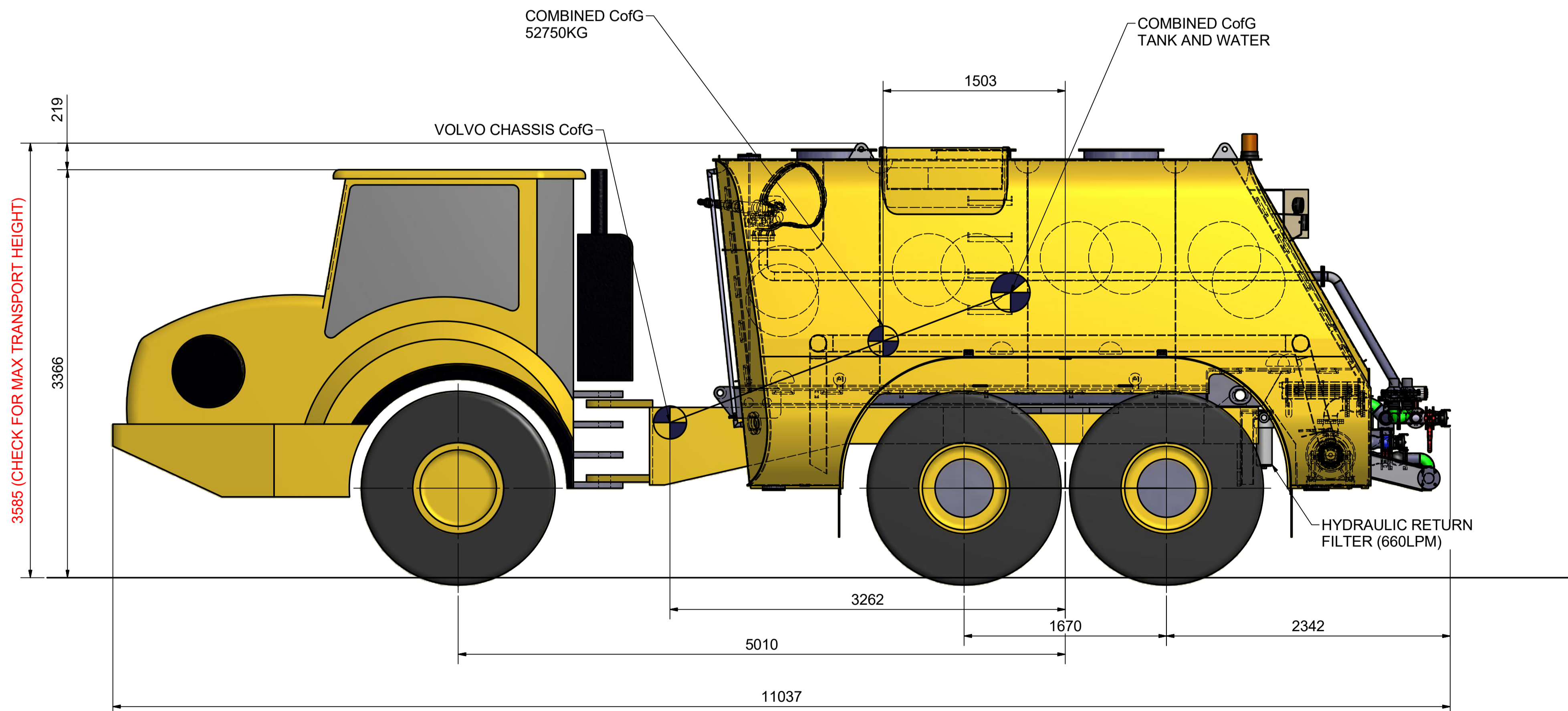
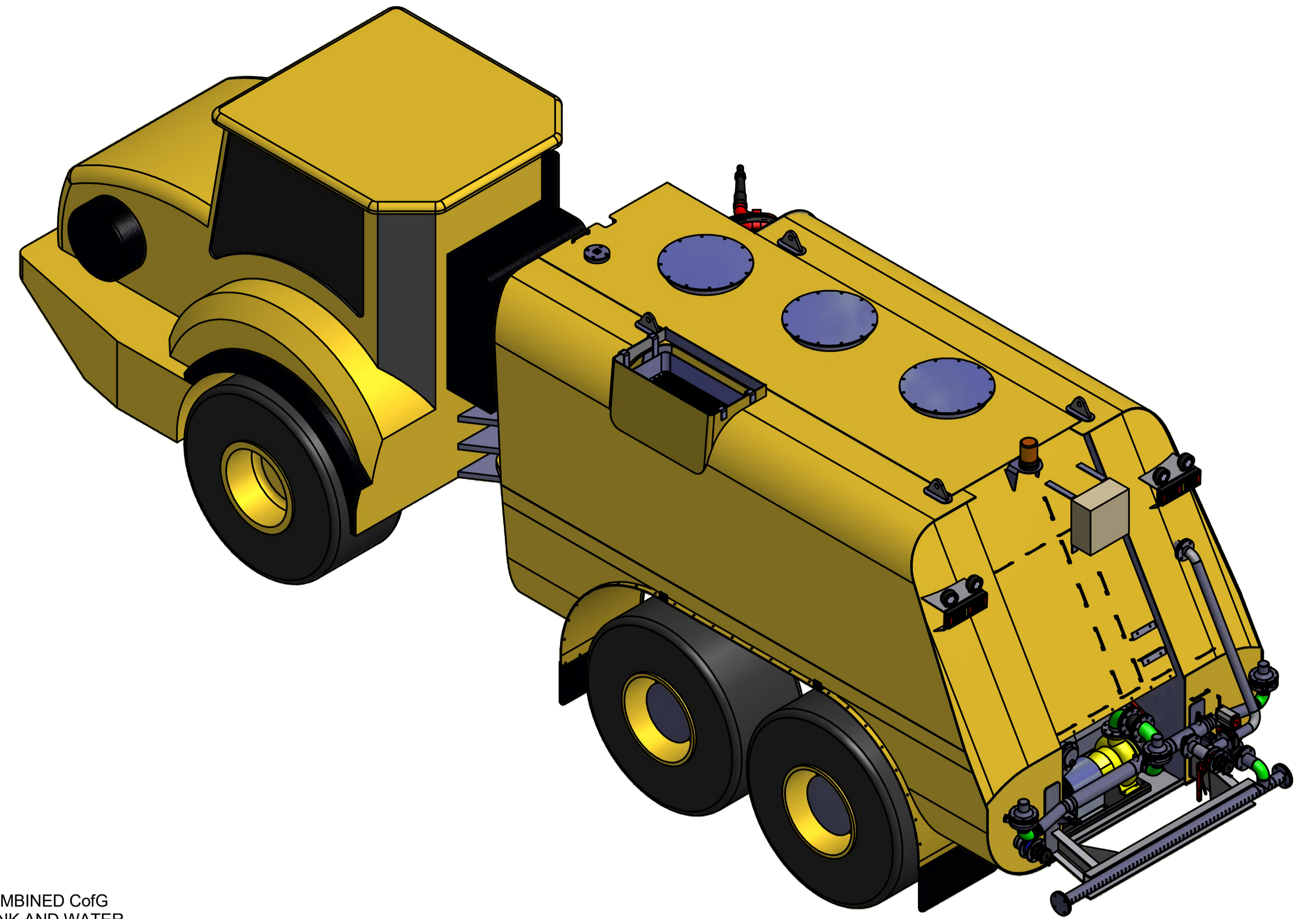

FRONT AXLE LOADING FULL 30%
15497Kg

REAR AXLE LOADING FULL 70%
36803Kg

JOB NUMBER -		THE CONTENTS OF THIS DRAWING REMAIN SOLELY THE PROPERTY OF BARTON ADT ENGINEERING. THIS DRAWING OR ITS CONTENT MAY NOT BE COPIED OR REPRODUCED WITHOUT THE PRIOR WRITTEN APPROVAL OF BARTON ADT ENGINEERING	
OFFICE	WORKSHOP	3rd ANGLE PROJECTION ALL DIMENSIONS ARE IN MILLIMETRES U.O.N. SCALE: AS NOTED	DRAWN - john kember
DATE ISS'D	DATE FAB'D		CREATED -
QTY. REQ'D	QTY. FAB'D		CHECKED -
			APPROVED -

VOLVO A30G
WATER TANKER



BARTON ADT ENGINEERING
EMAIL sales@bartonadtengineering.com
PHONE (+61) 407772864
WEB www.bartonadtengineering.com

DRG. VOLVO A30G TANK ASSY SURFACE SPECIAL	SHT. 2 of 2	SIZE A1	REV. A
-------------------------------------------	-------------	---------	--------